

## **VASOVIEW 7 xB Endoscopic Vessel Harvesting System** *Information for Prescribers*

**Caution: Federal (USA) law restricts this device to sale by, or on the order of a physician.**

### **Table of Contents**

1.0	DEVICE DESCRIPTION
1.1	VASOVIEW 7 xB Endoscopic Vessel Harvesting System
1.2	7 mm Extended Length Endoscope and Dissection Tip
1.3	Short Port Blunt Tip Trocar (BTT)
2.0	HOW SUPPLIED
3.0	INDICATIONS
3.1	VASOVIEW 7 xB Endoscopic Vessel Harvesting System
3.2	7 mm Extended Length Endoscope and Dissection Tip
3.3	Short Port BTT
4.0	CONTRAINDICATIONS
5.0	WARNINGS AND PRECAUTIONS
5.1	VASOVIEW 7 xB Endoscopic Vessel Harvesting System
5.2	7 mm Extended Length Endoscope and Dissection Tip
5.3	Short Port BTT
6.0	INSTRUCTIONS FOR USE
6.1	Sterilization of the 7 mm Extended Length Endoscope
6.2	Preparation of the Endoscope and Dissection Tip
6.3	Patient Preparation
6.4	Tunnel Dissection
6.5	Preparation of the BiSECTOR™ Bipolar Ligating Forceps
6.6	VASOVIEW 7 xB Endoscopic Vessel Harvesting System Insertion
6.7	Vessel Harvesting
6.8	Radial Artery Harvesting Feasibility Study Results
6.9	Generator Settings
7.0	HANDLING, STORAGE, AND CLEANING
7.1	7 mm Extended Length Endoscope

# MAQUET

---

8.0 WARRANTY

9.0 BIBLIOGRAPHY

10.0 GRAPHICAL SYMBOL DEFINITIONS

**Figure 1: VASOVIEW 7 xB Endoscopic Vessel Harvesting System**

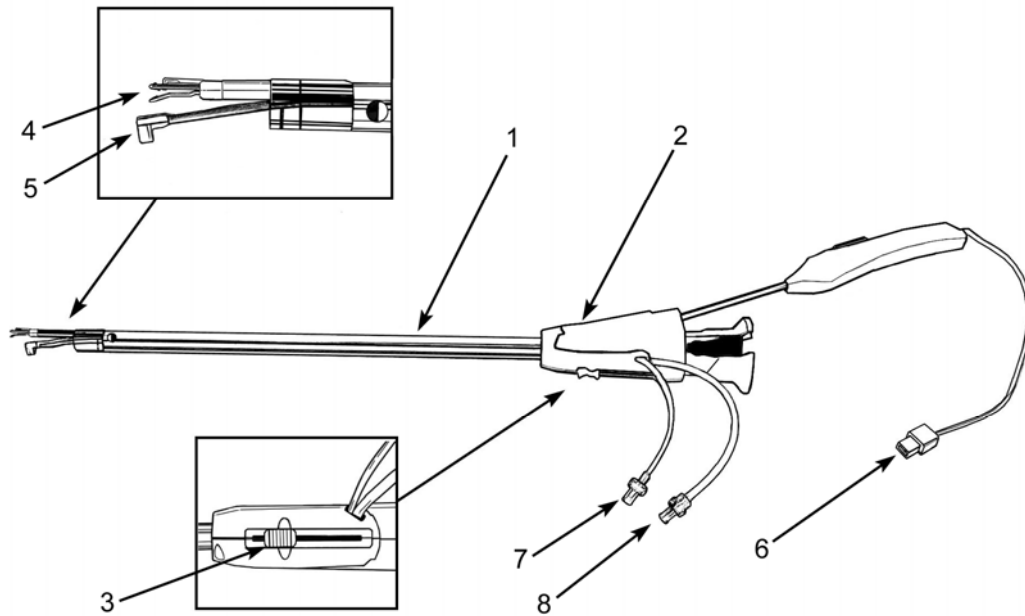

1. Harvesting Cannula
2. Tool Adapter Port
3. C-Ring Slider
4. BiSECTOR™ Bipolar Ligating Forceps
5. C-Ring
6. Electrical Connector
7. Scope Washer Connector
8. Distal Insufflation Connector

**Figure 2: 7 mm Extended Length Endoscope and Dissection Tip**

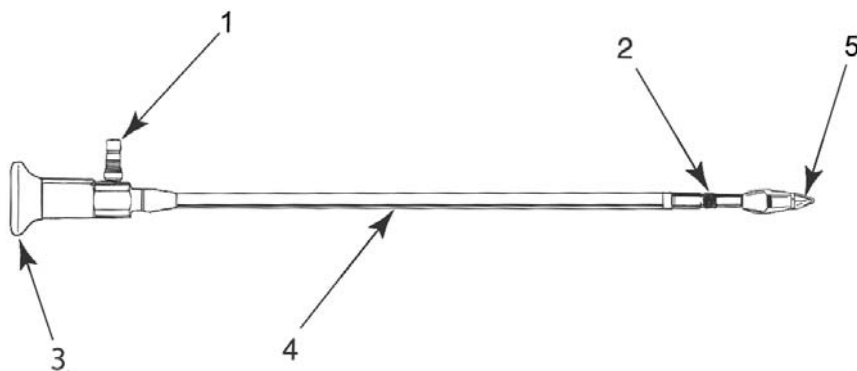

1. Illumination Port
2. Indicator Band
3. Eyepiece
4. Shaft
5. Dissection Tip

**Figure 3: Short Port BTT**

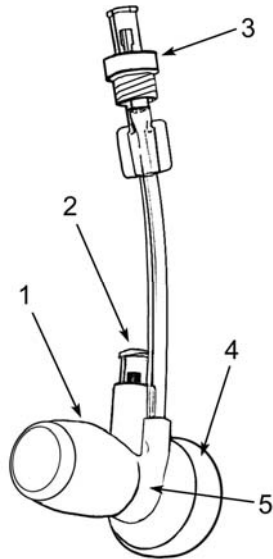

1. Balloon
2. Balloon Inflation Port
3. CO<sub>2</sub> Insufflation Port with one-way valve
4. Endoscope Seal or Cannula Seal
5. Body

**Read all information carefully before using.**

**Important:** These Instructions For Use are designed to assist in the use of the VASOVIEW 7 xB Endoscopic Vessel Harvesting System. They are not a reference to endoscopic surgery or techniques. Representative sources are listed in Section 9.0 of these Instructions for Use.

## **1.0 DEVICE DESCRIPTION**

### **1.1 VASOVIEW 7 xB Endoscopic Vessel Harvesting System**

The VASOVIEW 7 xB Endoscopic Harvesting System is designed for use in conjunction with the 7 mm Endoscope. The Harvesting Cannula has four lumens which house the Endoscope, C-Ring, distal lens washer tube and BiSECTOR™ Bipolar Ligating Forceps for ligation and division of vessel branches. The C-Ring/distal lens washer is independently controlled by a C-Ring Slider on the handle of the device for retraction of the vessel as well as washing of the distal tip of the Endoscope. The BiSECTOR can be extended/retracted through the main cannula by inserting it into the Tool Adapter Port, and rotated independently. Transection is achieved through mechanical actuation of the slide button. Bipolar coagulation is achieved using electrosurgical energy. Positioning of the device, coagulation, and mechanical cutting are performed under endoscopic visualization. This device is intended for use with the bipolar outputs of compatible generators.

### **1.2 7 mm Extended Length Endoscope and Dissection Tip**

The 7 mm Endoscope is a reusable product which consists of a stainless steel Shaft housing optical and illumination components. The proximal end has an Eyepiece for camera adapter attachment, and a light post for light cable connection; the camera adapter and light cable are not included with the 7 mm Endoscope.

The 7 mm Endoscope is designed to be used in conjunction with the removable Dissection Tip for blunt dissection of tissue and isolation of structures in the cavity. The Dissection Tip attaches to the distal end of the 7 mm Endoscope, and consists of a clear, blunt-tipped cone at the distal end for tissue dissection and visualization, and a larger bulb at the proximal end for dilation of the cavity.

### **1.3 Short Port Blunt Tip Trocar (BTT)**

The Short Port Blunt Tip Trocar (BTT) is used to provide a port of access for insertion of endoscopic instruments into an incision site. The device consists of a main body with a Balloon on the distal end, a Balloon Inflation Port, an Endoscope Seal on the proximal end, and an external port with a one-way valve for gas insufflation. It also includes a Cannula Seal to allow insertion of the Harvesting Cannula. The Balloon minimizes leakage and secures the port. A 30 cc syringe is provided for inflation/deflation of the Balloon.

## 2.0 HOW SUPPLIED

The VASOVIEW 7 xB is sterile unless the package is opened or damaged. The method of sterilization is gamma irradiation. The product is designed for single use. **Do not reuse or resterilize.** Contents of the VASOVIEW 7 xB Endoscopic Vessel Harvesting System: One (1) VASOVIEW Harvesting Cannula, One (1) BiSECTOR™ Bipolar Ligating Forceps, One (1) 5 cc Syringe, One (1) Short Port Blunt Tip Trocar (BTT) with Endoscope Seal, One (1) VASOVIEW Harvesting Cannula Seal, One (1) 30 cc Syringe, One (1) Dissection Tip.

**7 mm Extended Length Endoscope-** The 7 mm Endoscope (sold separately) is a reusable device and is supplied non-sterile. It must be cleaned and sterilized prior to each use.

**Short Port BTT-** The Short Port BTT is sterile unless the package is opened or damaged. The method of sterilization is gamma irradiation. The product is designed for single use. **Do not reuse or resterilize.**

## 3.0 INDICATIONS

### 3.1 VASOVIEW 7 xB Endoscopic Vessel Harvesting System

The VASOVIEW 7 xB Endoscopic Vessel Harvesting System is indicated for use in minimally invasive surgery allowing access for vessel harvesting, and is primarily indicated for patients undergoing endoscopic surgery for arterial bypass. It is indicated for cutting tissue and controlling bleeding through coagulation, and for patients requiring blunt dissection of tissue including dissection of blood vessels, dissection of blood vessels of the extremities, dissection of ducts and other structures in the extraperitoneal or subcutaneous extremity and thoracic space. Extremity procedures include tissue dissection/vessel harvesting along the saphenous vein for use in coronary artery bypass grafting and peripheral artery bypass or the radial artery for use in coronary artery bypass grafting. Thoracoscopic procedures include exposure and dissection of structures external to the parietal pleura, including nerves, blood vessels and other tissues of the chest wall.

### 3.2 7 mm Extended Length Endoscope and Dissection Tip

The 7 mm Extended Length Endoscope with Dissection Tip is indicated for visualization of a surgical cavity and dissection in endoscopic procedures and other minimally invasive surgical procedures allowing access for vessel harvesting, and is primarily indicated for patients undergoing endoscopic vessel harvesting for arterial bypass. It is indicated for patients requiring endoscopic tissue separation of the extraperitoneal or subcutaneous extremity and thoracic space. Extremity procedures include tissue dissection / vessel harvesting along the saphenous vein for use in coronary artery bypass grafting and peripheral artery bypass or radial artery for use in coronary artery bypass

grafting. Thoracoscopic procedures include exposure and dissection of structures external to the parietal pleura, including nerves, blood vessels, and other tissues of the chest wall.

### 3.3 Short Port BTT

The Short Port BTT has applications for surgery in the saphenous vein or radial artery for establishment of a port of entry for endoscopic instruments.

## 4.0 CONTRAINDICATIONS

VASOVIEW 7 xB Endoscopic Vessel Harvesting System, 7 mm Extended Length Endoscope and Dissection Tip, and Short Port BTT are contraindicated in situations where minimally invasive surgery is contraindicated.

## 5.0 WARNINGS AND PRECAUTIONS

### 5.1 VASOVIEW 7 xB Endoscopic Vessel Harvesting System

1. Read all instructions carefully. Failure to properly follow the instructions, warnings and precautions may lead to serious surgical consequences or serious injury to the patient.
2. Minimally invasive surgical procedures should be performed only by individuals adequately trained and familiar with such surgical techniques. Consult medical literature regarding techniques, complications, and hazards prior to performance of these procedures.
3. **Sterility:** The VASOVIEW 7 xB System is sterile unless the package is damaged or opened. The method of sterilization is gamma irradiation. The VASOVIEW 7 xB System is designed for single use. **Do not reuse or resterilize.**
4. Before endoscopic instruments and accessories from different manufacturers are employed in a procedure, verify compatibility and ensure that electrical isolation and grounding of these instruments is not compromised.
5. A thorough understanding of the principles and techniques involved in electrosurgical procedures is essential to avoid shock and burn hazards to both the patient and operator(s) and damage to medical instrumentation.
6. The VASOVIEW 7 xB Endoscopic Vessel Harvesting System is for use with the bipolar outputs of electrosurgical generators only.

7. **FOR INTERMITTENT OPERATION ONLY:** Do not apply continuous cautery energy.
8. Do not exceed 30 watts in any mode.
9. Use generators listed in the specified Mode and Setting Range only.
10. Do not use with Codman Malis generators.
11. Handle the Endoscope carefully to avoid breakage. Regularly check the orientation of the camera before advancing.
12. To avoid damage to delicate tissue, advance the cannula gently.
13. Always advance the C-Ring and BiSECTOR™ Bipolar Ligating Forceps under endoscopic visualization. Ensure adequate visualization of BiSECTOR ends and surgical site prior to application of electrosurgical energy.
14. Always inspect the surgical site for hemostasis. If hemostasis is not present, appropriate techniques should be applied to achieve hemostasis.
15. In endoscopic procedures which use gas insufflation, venous gas embolism is a very rare (approximately 1 in 10,000 cases) but potentially serious complication that may occur. Its occurrence is signaled by cardiovascular collapse (sudden, severe hypotension) and a precordial murmur. If gas embolism is suspected during a procedure, discontinue gas insufflation and place the patient in a left lateral and a slight Trendelenburg position.
16. When performing radial artery harvesting, the radial artery harvesting procedure should be performed prior to placing the patient on cardiopulmonary bypass.
17. Do not touch the coagulating surfaces while the device is activated. This may cause injury.

## **5.2 7 mm Extended Length Endoscope and Dissection Tip**

1. The Endoscope is a reusable instrument that is supplied non-sterile. Thoroughly clean and sterilize the Endoscope prior to each use. Follow recommended cleaning and sterilization instructions as described in these Instructions for Use, Sections 6.1 and 7.1.

2. The Endoscope is a fragile instrument. Handle carefully to avoid breakage. Bending of the Shaft or dropping the Endoscope may damage the optics or other internal components, making the Endoscope inoperable. Store in a protective tray whenever possible.
3. The Dissection Tip is sterile unless the package is opened or damaged. The Tip is designed for single use. **Do not reuse or resterilize the Dissection Tip.**
4. Whenever using endoscopic illumination equipment, ensure that the light cable connectors never rest on flammable materials such as surgical drapes, towels, etc.
5. If Prevacuum or Gravity steam sterilization (autoclave) are used, the Endoscope may have a shorter life due to harsher sterilization environment. Inspect the Endoscope after each steam sterilization cycle for damage.
6. Do not cool a hot Endoscope after sterilization by rapidly exposing it to air or liquid. Sudden temperature changes may cause glass components to crack.
7. Do not “flash” steam sterilize (autoclave) the Endoscope. Flash (i.e., unwrapped) steam sterilization cycles introduce sudden temperature changes, which may cause glass components to crack.

### 5.3 Short Port BTT

1. Sterility: The product is sterile unless the package is damaged or opened. The method of sterilization is gamma irradiation. The product is designed for single use. **Do not reuse or resterilize.**
2. Balloon products must be treated with care. Damage to the Balloon by instruments used during insertion and in the course of a procedure may result in Balloon rupture.
3. The Short Port BTT balloon contains natural rubber latex that is encapsulated by a silicone coating such that latex is not intended to come in contact with the patient or the user. If the outer layer of the balloon on the Short Port BTT is damaged, natural rubber latex may be exposed. Natural rubber latex may cause allergic reactions.
4. Over inflation of the Short Port BTT Balloon may result in Balloon rupture. Do not inflate with more than 25 cc of air.

## 6.0 INSTRUCTIONS FOR USE

The following instructions are recommended for proper function of the VASOVIEW 7 xB™ Endoscopic Vessel Harvesting System. It is not a reference for endoscopic surgery techniques.

### 6.1 Sterilization of the 7mm Extended Length Endoscope

Remove the Endoscope from the packaging and discard the protective cap. Use one of the methods listed below to sterilize the 7 mm Extended Length Endoscope.

1. 100% Ethylene Oxide Sterilization per ANSI/AAMI/ISO 11135, with the following parameters:
  - Configuration: Wrapped with 2 ply muslin or equivalent
  - Preconditioning: 57°C (135°F) temperature, 70% relative humidity, 1-hour minimum exposure.
  - Conditioning and Sterilization: 57°C (135°F) temperature, 70% ± 5% relative humidity, 100% ethylene oxide (600 ± 25 mg/L concentration), 2 hour minimum exposure
  - Aeration: 57°C (135°F) temperature, 12-hour minimum aeration.

**NOTE:** Use a protective tray during sterilization and storage of the endoscope.

Note: Ethylene Oxide method is recommended for longer Endoscope life.

2. Prevacuum Steam Sterilization (Prevacuum Autoclave) with the following parameters:
  - Configuration: Wrapped with 2 ply muslin or equivalent
  - Exposure Time: 4 minutes
  - Temperature: 132°C (270°F)

**NOTE:** Use a protective tray during sterilization and storage of the endoscope.

3. Gravity Steam Sterilization (Gravity Autoclave) with the following parameters:
  - Configuration: Wrapped with 2 ply muslin or equivalent
  - Exposure time: 15 minutes
  - Temperature: 132°C (270°F)

**NOTE:** Use a protective tray during sterilization and storage of the endoscope.

4. STERIS SYSTEM 1: (liquid peracetic acid) compatible. Use STERIS 20 sterilent and C1200 or C1220 processing tray..

**NOTE:** Use a protective tray during storage of the endoscope.

5. STERRAD 100s, 50, 200 compatible. Use STERRAD instrument tray. Double wrap with KIMGUARD sterile wrap or equivalent.

**NOTE:** Use a protective tray during storage of the endoscope.

## 6.2 Preparation of the Endoscope and Dissection Tip

1. Attach an appropriate light cable to the Illumination Port on the Endoscope until securely fastened. (When not attached to the scope, do not place the light cable on flammable materials such as surgical drapes or towels.) Attach the opposite end of the light cable to a Xenon light source (maximum 300W bulb).
2. Attach an appropriate camera adapter to the Eyepiece of the Endoscope. Do not attempt to remove the Eyepiece from the Endoscope. Attach the opposite end of the camera adapter cable to the appropriate port of the camera box.
3. Focus the image from the Endoscope using the focus ring on the camera adapter. Picture orientation can be corrected by rotating the camera adapter on the Endoscope Eyepiece to the appropriate position.
4. White balance the camera in accordance with the camera manufacturer's instructions for use.
5. Prior to each use, verify that image quality and light intensity are adequate to perform the procedure; if inadequate, remove the Endoscope from operation. Inspect the Endoscope for visible damage (e.g., cracks, loose components); if found, remove the Endoscope from operation.
6. Attach the removable Dissection Tip to the distal end of the Endoscope. Thread the Dissection Tip onto the Endoscope until the proximal edge of the Dissection Tip lines up with the Indicator Band on the Endoscope Shaft, and the Dissection Tip is securely attached to the Endoscope.

## **6.3 Patient Preparation**

1. Prepare the patient in accordance with standard surgical techniques.

## **6.4 Tunnel Dissection**

1. Using an open technique, make an initial 2 cm incision and locate the vessel. Slide the Short Port BTT with Endoscope Seal up the Endoscope Shaft to the proximal hub of the Endoscope. Insert the Dissection Tip into the subcutaneous space anterior to the vessel. Advance the instrument toward the target tissue, keeping the tip in contact with anterior surface during the dissection process. Advance the instrument approximately 3 – 4 cm, and then slide the Short Port BTT into the incision. Inflate the BTT Balloon with up to 25 cc of air through the Balloon Inflation Port. Connect the gas line to the CO<sub>2</sub> Insufflation Port and infuse CO<sub>2</sub> gas at a low rate of 3 – 5 L/min to a pressure of 10 – 12 mm Hg. Gas insufflation holds the dissected tunnel open for improved visualization.
2. Continue advancing the Endoscope and Dissection Tip along the anterior aspect of the vessel, until the desired vessel length is dissected. Monitor progress of dissection via the Endoscope. Withdraw the Endoscope until the Dissection Tip is at the distal end of the Short Port BTT and then advance the Endoscope along the posterior aspect of the vessel, dissecting gently and thoroughly around vessel branches as they are encountered.
3. Should the image become compromised, verify that all equipment is correctly connected to the Endoscope. If required, remove the Endoscope and Dissection Tip, and carefully clean the distal tip of the Endoscope and / or the Dissection Tip. If the image is still unacceptable, remove the Endoscope from operation.
4. Upon completion of tissue dissection, remove the Endoscope from the tunnel, and remove the Dissection Tip from the Endoscope.
5. The Harvesting Cannula may be used to complete isolation of the vessel. Upon completion of the endoscopic procedure, the working space may be quickly deflated by removing the Harvesting Cannula from the Short Port BTT.

## 6.5 Preparation of the BiSECTOR™ Bipolar Ligating Forceps

1. Carefully remove the BiSECTOR from its shipping package. Do not use if damaged or opened. Inspect to ensure no damage has occurred during transit.
2. Insert the Electrical Connector into the appropriate extension cord.
3. Pre-test the BiSECTOR to verify complete electrical activity and generator setting:
  - Soak a sterile 4" x 4" (10.16 cm x 10.16 cm) gauze pad with saline.
  - Touch both electrodes against the soaked 4" x 4" (10.16 cm x 10.16 cm) gauze pad.
  - WARNING: DO NOT TOUCH THE COAGULATING SURFACES WHILE THE DEVICE IS ACTIVATED. THIS MAY CAUSE INJURY.**
  - Activate the electrosurgical function by depressing the COAG pedal on the footswitch.
  - Steam generation from the soaked 4" x 4" (10.16 cm x 10.16 cm) gauze pad and the electrodes indicates active power and a complete circuit.
  - NOTE:** If there is no steam during the Pre-test:
    - Add more saline to the pad.
    - Ensure that both electrodes are in contact with the saline-soaked pad.
    - Verify that the electrosurgical generator power switch is ON, and in the foot switching mode.
    - Verify proper connection of the Electrical Connector on the BiSECTOR™ Bipolar Ligating Forceps to the extension cord, and the extension cord to the generator.
    - Check generator function and setting. For power settings, see enclosed chart.
    - Turn power up in small increments. Do not exceed 30 Watts.
    - Decrease the amount of pad surface contacting the coagulating surfaces.

If steam is still not observed, **DO NOT** use the device and call Customer Service at (888) 880-2874. For outside the United States, please call Customer Service at (408) 635-6800.

**NOTE:** Due to variations in individual patient anatomy and individual physician technique, the following steps may vary and should be considered recommendations only.

## 6.6 VASOVIEW 7 xB Endoscopic Vessel Harvesting System Insertion

1. After completing tunnel dissection, attach the Cannula Seal to the Short Port BTT.
2. Insert the 7 mm Endoscope into the Harvesting Cannula until it snaps into place.
3. Ensure power is off and BiSECTOR blade is retracted prior to insertion and withdrawal through the Harvesting Cannula. Hold the BiSECTOR shaft approximately 6" (or 15 cm.) from the tips before inserting through the Tool Adapter Port. If desired, Surgilube (or another water-soluble lubricant) may be used on the BiSECTOR shaft. Advance the BiSECTOR through the Tool Adapter Port of the Harvesting Cannula, but do not advance the tips of the BiSECTOR beyond the end of the Harvesting Cannula. Ensure blade is retracted while moving device within the tunnel to avoid inadvertent trauma to tissues. Advance the blade only when device is in view.
4. Slide the Harvesting Cannula through the Short Port BTT and into the harvesting space. Advance the distal end of the Cannula to the target location.  
**NOTE:** To ensure minimal leakage through incision:
  - Ensure the BTT port Balloon is inflated (up to 25 cc of air).
  - Apply gentle backpressure to the Balloon to ensure the incision is sealed.
  - If necessary, use suture to reduce the incision size.
5. Ensure the gas line is connected to the CO<sub>2</sub> insufflation Port on the Short Port BTT or to the Distal Insufflation Connector on the Harvesting Cannula. Infuse with CO<sub>2</sub> gas at a flow rate of 3 – 5 L/min to a pressure of 10-12mmHg. Gas insufflation holds the dissected tunnel open for improved visualization.  
**NOTE:** To ensure adequate visualization of the tunnel:
  - Confirm there is adequate gas in the CO<sub>2</sub> tank.
  - Confirm the CO<sub>2</sub> tank valve is open.
  - Confirm the CO<sub>2</sub> insufflator is turned on.
  - Confirm the CO<sub>2</sub> tubing is properly connected.
  - Confirm gas is present at the delivery end of the CO<sub>2</sub> tubing.
  - Switch gas line to Distal Insufflation Connector if originally attached to the Short Port BTT Insufflation Port.
  - Slowly withdraw the Harvesting Cannula back towards the Short Port BTT until the tunnel re-expands.
  - Perform blunt dissection or use BiSECTOR™ Bipolar Ligating Forceps to cut through the fascia to modify the tunnel size.
  - Branch ligation may be done to increase tunnel size.

**NOTE:** If blood or other tissue obscures the distal lens of the Endoscope, advance the C-ring Slider to position the distal lens washer. Attach the 5 cc syringe of saline to the blue Scope Washer Connector and squeeze the syringe to spray saline and clean the Endoscope lens. Alternatively, the Endoscope can be removed and the distal lens cleared using a sterile 4" x 4" (10.16 cm x 10.16 cm) gauze pad.

6. Turn on the generator to the recommended start setting and to the recommended mode listed on the generator chart.  
**WARNING: DO NOT EXCEED 30 WATTS.**  
If wattage setting is too high, tissue may dry out rapidly causing sticking and hemostasis may be compromised.

## 6.7 Vessel Harvesting

1. Under endoscopic visualization, extend the C-Ring to the targeted vessel by advancing the C-Ring Slider forward. The C-Ring may also be positioned by rotating the VASOVIEW Harvesting Cannula around the Endoscope. If desired, use the C-Ring to retract the main trunk of the vessel for additional exposure of the branches.
2. Position the device as desired. With tips in view, advance the blade into the cutting position. Engage the target vessel between the electrodes by advancing the flare tipped electrode over the tissue until it is firmly between the device electrodes. Manually rotate the BiSECTOR as necessary to access the target vessel.
3. Activate the electrocautery of the VASOVIEW 7 xB Endoscopic Vessel Harvesting System via the footswitch. Coagulation occurs between the noninsulated wires of the electrodes. Electrode surfaces should be in contact with tissue for optimum coagulation. Tissue dehydration and blanching should indicate successful coagulation. To use as a spot coagulator, contact tissue with BiSECTOR electrodes. After coagulation, retract the slide button on the device handle to transect the coagulated tissue. Gently remove device from tissue after cutting. The BiSECTOR™ Bipolar Ligating Forceps should be in view when cutting or coagulating per standard endoscopic technique.  
**NOTE:** Applying gentle tension on the vessel by rotating the BiSECTOR while the electrodes have engaged the target vessel may facilitate transection.
4. To clean the cutting and coagulating surfaces, use 4" x 4" (10.16 cm x 10.16 cm) gauze pad(s) soaked with saline solution. For optimum performance, keep the blade and electrode surfaces free of debris.

5. Upon completion of use of the BiSECTOR, turn electrocautery power OFF and ensure the BiSECTOR is retracted through the Tool Adapter Port. Then withdraw the C-Ring into the Harvesting Cannula before removing the device from the tunnel.
6. To remove the Short Port BTT, place the syringe in the Balloon Inflation Port with the plunger depressed. The Balloon will deflate, pushing the plunger out and filling the syringe. Remove the Short Port BTT.
7. Remove harvested vessel per standard procedure.

**NOTE:** Always inspect the surgical site for hemostasis. If hemostasis is not achieved, appropriate techniques should be applied to control bleeding.

## 6.8 Radial Artery Harvesting Feasibility Study Results

**Objective:** To evaluate the safety of the VASOVIEW Endoscopic Vessel Harvesting System (VASOVIEW Uniport Plus Dissection Cannula) when used to harvest radial arteries in patients who undergo coronary artery bypass surgery.

**Methods:** Seven (7) patients undergoing CABG and meeting study criteria were enrolled and consented in a single-center feasibility study. Two patients were excluded from the primary endpoint analysis for meeting an exclusion criteria and enrolling under a previous protocol version. Data was collected at baseline, perioperatively, and post-operatively up to discharge and at 30 days.

**Results:** The radial artery was successfully harvested in all seven (7) patients with minor donor arm complications and patency was demonstrated for all five (5) patients who underwent angiography at 30 days. All 5 radial artery grafts were reported to be patent by the core lab. Minimal stenosis (25%) was found in all of the radial artery grafts at the anastomotic site with the average lesion length of 2.22 +/- 0.56 mm. TIMI 3 flow was reported for each radial artery graft with no calcification or tortuosity. One patient experienced stenosis of a native coronary artery which required PTCA with stenting. A summary of the feasibility study results is provided in Table 1.

**Table 1. Radial Artery Harvesting Feasibility Study Results**

<b>Category Results</b>	<b>(N=7)</b>
Age in years, mean (range)	57.8 (41-69)
Gender (% male)	86%
<b>Primary Endpoint</b>	
Patency (n)	100% (5/5)*
<b>Secondary Endpoint</b>	
Arm Complications	
Hand/thumb weakness	0
Dysesthesia/paresthesia	2
Motor deficit	0
Nerve damage	0
Hematoma	0
Infection/wound complication**	1
MACE	0
Stroke	0
Hemorrhage	0
*2 patients did not undergo angiogram **erythema	

## 6.9 Generator Settings

**NOTE:** The Wolf generators are compatible with MAQUET Cardiovascular Extension cord P/N 1837. All other generators listed are compatible with MAQUET Cardiovascular Extension cord P/N 1838.

**Table 2. Generator Settings**

<b>Generator</b>	<b>Model</b>	<b>Mode</b>	<b>Setting Range</b>
ValleyLab	Force 2	Bipolar	15-25 watts
ValleyLab	Force 4	MicroBipolar Precise	15-25 watts
ValleyLab	Force 30	Bipolar	15-25 watts
ValleyLab	Force 40	Bipolar	15-25 watts
ValleyLab	SSE2L	Bipolar Coag	2-4.5
ValleyLab	Force 4B	Precise Bipolar	15-25 watts
Valley Lab	Force FX	Standard	15-20 watts
Conmed	Excalibur	Bipolar Coag	15-25 watts
Conmed	Excalibur Plus	Bipolar Coag	15-25 watts
Conmed	Bistat	General	15-25 watts
Conmed	Sabre 180	Bipolar Coag	15-25 watts
Conmed	Sabre 2400	Bipolar Coag	15-25 watts
Davol (Bard)	5000	Bipolar Cut	15-25 watts
Wolf	2075 U	Bipolar	3-5
Wolf	2085	Bipolar	3-5
Wolf	2352	Bipolar	15-25 watts
Erbe	ICC 350	Auto Bipolar	15-30 watts
Ethicon	Pegasys	Bipolar	15-25 watts

**WARNING: DO NOT EXCEED 30 WATTS IN ANY GENERATOR SETTING!**

**CAUTION:** This device should not be used with generators that have bipolar outputs greater than 1000 volts max (peak to peak).

**NOTE:** If you have an unlisted generator, please call Customer Service.

## 7.0 HANDLING, STORAGE and CLEANING

### 7.1 7 mm Extended Length Endoscope

The Endoscope must be thoroughly cleaned prior to resterilization.

1. Upon completion of the procedure, cover the soiled Endoscope with a towel moistened with distilled water, to prevent soil from drying out before cleaning.
2. If present, remove the light cable adapter from the Endoscope.
3. Soak the Endoscope in Steris Klenszyme™ enzymatic solution (prepared per manufacturer's instructions) for a minimum of 2 minutes. Rinse thoroughly with distilled water.
4. Manually clean the Endoscope with Steris Manu-Klenz™ detergent (prepared per manufacturer's instructions). Use a soft, non-abrasive cloth or brush to clean the Endoscope, especially threads, grooves, and crevices, until no visible soil remains on the Endoscope. Rinse thoroughly with distilled water.
5. Thoroughly dry the Endoscope with clean, lint-free material.

## 8.0 WARRANTY













MAQUET Cardiovascular LLC (MAQUET) warrants that reasonable care has been used in the design and manufacture of this system and its individual components. **This warranty is in lieu of and excludes all other warranties not expressly set forth herein, whether express or implied by operation of law or otherwise, including, but not limited to, any implied warranties of merchantability or fitness for a particular purpose.** Handling, storage, cleaning and sterilization of this system, including any disposable components, power supply, capital equipment, or other components, as well as other factors relating to the patient, diagnosis, treatment, surgical procedures and other matters beyond MAQUET's control directly affect the instrument and the results obtained from its use. MAQUET's obligation under this warranty is limited to the repair or replacement of this system and its components for a period of one year from the date of purchase with respect to parts and labor, and MAQUET shall not be liable for any incidental or consequential loss, damage or expense directly or indirectly arising from the use of this system. In the event of a warranty claim, the purchaser must allow MAQUET, at its option, to inspect the system and its components and the purchaser must reasonably cooperate with MAQUET with respect to verifying the warranty claim of the purchaser. In the event that a warranted defect is discovered, the sole remedy available to purchaser will be for MAQUET, at its option, to repair or replace the affected component(s). Repairs must be made by an authorized MAQUET site or this warranty will be null and void. This Warranty applies only to products that are defective and does not cover failures or damages due to normal wear, abuse, misuse, tampering, lack of proper maintenance, and force majeure. MAQUET neither assumes, nor authorizes any other person to assume for it, any other or additional liability or responsibility in connection with this system. **MAQUET assumes no liability with respect to instruments reused, reprocessed or resterilized and makes no warranties, express or implied, including but not limited to merchantability or fitness for a particular purpose, with respect to such instruments.** With regard to MAQUET products that are labeled **FOR SINGLE USE ONLY** or **DO NOT REUSE**, this warranty is null and void following the single use of such products.

This product and/or its use are protected under one or more of the following United States patents: 5,352,222; 5,514,134; 5,697,946; 5,895,353; 5,993,384; 6,162,173; 6,176,825; RE 36,043; 6,406,425; 6,830,546. Additional patents pending.

## 9.0 BIBLIOGRAPHY

- (1) G. Berci, Endoscopy, Appleton-Century-Crofts, 1976, pp. 384-385.
- (2) J.M. Phillips, Laparoscopy, Williams and Wilkins Co., 1977, pp. 91-95.
- (3) J.F. Hulka, Textbook of Laparoscopy, Grune and Stratton.
- (4) D.M. Meyer, et al, Histologic Evidence of the Safety of Endoscopic Saphenous Vein Graft Preparation, Ann Thorac Surg, 2000; 70:487-91.

## 10.0 GRAPHICAL SYMBOL DEFINITIONS

 Catalogue Number :	 Sterilization by Irradiation
 Lot Number:	 Non-Sterile
 Serial Number:	 Type CF Applied Part
 Use By:	 Manufacturer:
 Do Not Reuse	 Date of Manufacture:
 Attention: See Instructions For Use	 Contents (Numeral represents quantity of units inside)
 Federal Law (USA) restricts this device to sale by or on the order of a physician.	

MAQUET is a Trademark of MAQUET GmbH & Co. KG

Copyright 2008 MAQUET Cardiovascular LLC or its affiliates. All rights reserved.

BiSECTOR is a trademark of Gyrus Group PLC.

MAQUET Cardiovascular LLC

45 Barbour Pond Drive

Wayne, NJ 07470 USA

US Toll-free Tel: (888) 880-2874 Tel: (408) 635-6800

US Toll-free Fax: (888) 899-2874 Fax: (408) 635-6801